

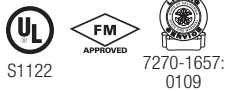

LIFE SAFETY & INCIDENT MANAGEMENT

Fixed Temperature Heat Detectors

283B-PL, 284B-PL



Overview

PL Series heat detectors offer fixed temperature detection. If the temperature of the center disk rises to the sensor's rated temperature, the fixed temperature element activates. This closes contacts in the sensor and transmits an alarm condition to the fire alarm control panel. The fixed temperature element is non-restorable and, when activated, the detector must be replaced. The need for replacement is indicated when the center disk has fallen free from the detector .

Standard Features

- UL listed for 50 ft. (15.2m) spacing
- Single pole — normally open contact
- Low profile with mounting plate
- Pure white finish
- Mounting flexibility with screw terminals
- Easy twist-on installation
- Positive operating indication

Application

Heat detectors are most suitable for environments where rapid fire development can be expected. When selecting the location on the ceiling for the heat sensor, do not locate it in direct path of hot or cold air flow. Refer to the detector specifications for the recommended maximum spacing. Earlier detector response may be obtained by reducing the spacing between detectors.

Installation

PL Series heat sensors come standard with a white plastic reversible mounting plate. The plate is designed for surface or flush mounting and installs directly to a standard North American 3½ or 4 inch octagon box. Once the mounting plate is fixed, a simple twist will lock the sensor in place. It can be removed using a screwdriver to release the tamper-resistant locking finger. This helps prevent unauthorized removal.



LIFE SAFETY & INCIDENT MANAGEMENT

Contact us...

Email: edwards.fire@fs.utc.com
 Web: Edwards-fire.com

EDWARDS is a UTC brand.
 1016 Corporate Park Drive
 Mebane, NC 27302

© 2017 United Technologies Corporation.
 All rights reserved.

Mounting

The plastic mounting plate is molded to accommodate exposed wiring.

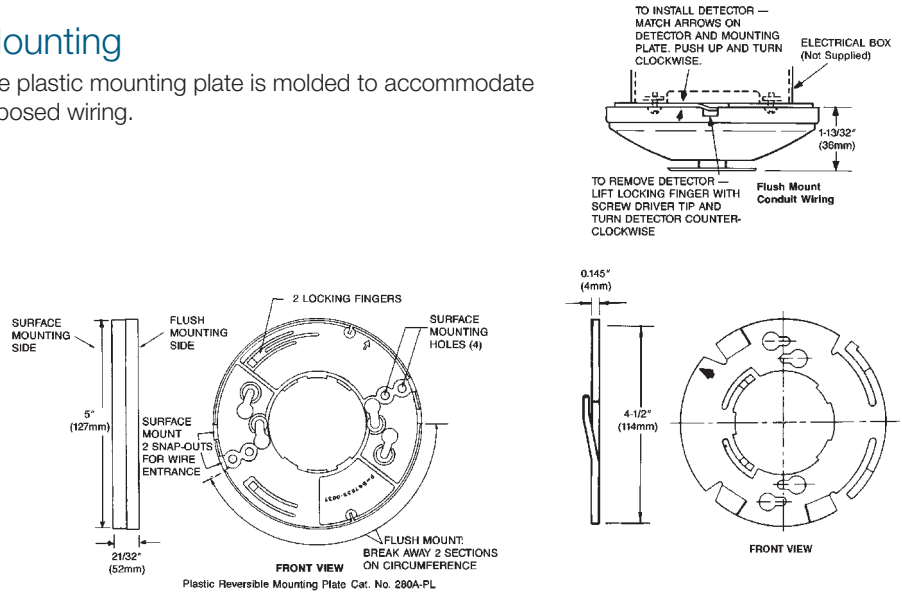

WARNING – Use For Property Protection Only: Heat sensors do not protect life against fire and smoke. In most fires, hazardous levels of smoke, heat and toxic gases can build up before a heat detector would initiate an alarm. Independent studies indicate that heat detectors should only be used when property protection alone is involved. In cases where life safety is a factor, the use of smoke detectors is recommended.

Under no circumstances should heat detectors be relied upon as the sole measure to ensure fire safety. However, if they are spaced in accordance with the directions in the Specifications table, these sensors can contribute, within an overall fire safety program, to reducing the risk of avoidable property losses.

Specifications

Catalog Number	283B-PL	284B-PL
UL Temperature Rating	135°F (57°C)	194°F (90°C)
UL Max Ambient Temp. at Ceiling	100°F (38°C)	150°F (66°C)
Detector Type	Fixed Temperature	
UL Recommended Coverage*	2,500 ft. ² (232 m ²)	
UL Recommended Spacing	50 ft. (15.2 m)	
FM Recommended Spacing	30 ft. (9.14 m)	
UL Maximum Distance from Wall	25 ft. (7.6m) from any wall or projection extending down from the ceiling more than 12 inches (305 mm)	
Contacts – Rating	Single Pole Normally Open 3.0 amps at 6 to 125 Vac; 1.0 amp at 6 to 24 Vdc; 0.3 amps at 125 Vdc; 0.1 amps at 250 Vdc	
Operating Environment	Indoor – Dry	
Agency Listings	UL, FM, CSFM	

* Maximum detector coverage has been determined by UL to provide detection time equal to sprinkler devices spaced at 10 ft (3.05m) intervals on a smooth ceiling 15 feet 9 inches (4.8m) high. Higher ceilings may adversely affect detection time. Earlier detection may be obtained by reducing the spacing between sensors. (See NFPA 72, Chapter 5)

Ordering Information

Cat. No.	Description	Ship Wt. lb (kg)
283B-PL	Heat Detector, 135°F (57°C), Fixed Temperature	1.0 (0.5)
284B-PL	Heat Detector, 194°F (90°C), Fixed Temperature	

Detector Accessories		
280A-PL	Plastic Mounting Plate – White, Reversible (included)	